

FRENIC4000VM5/FM5

DC-link Inverter with Vector and V/f Control

HIGH-SPEED DATA COLLECTION SYSTEM

REMOTE WATCH OF USS BASE ANALOG OUTPUT FOR CHART

FRENIC4000VM5/FM5

SPACE-SAVING LOW-LEVEL MAINTENANCE

AC Adjustable Speed Drive

Compact and Easy Maintenance IGBT PWM Inverter

Multi-stage stacking structure adopted

300kVA or less capacity inverters have a consistent plug-in structure, enabling up to 12 units to be mounted on a single panel and allowing considerable space saving.

Units of various sizes, and vector (VM5) and V/f controls (FM5) can be mixed (*).

Inverter capacity [kVA]	No. of units mountable per panel
10, 15, 25	12 Maximum
38, 50, 75	8 Maximum
100, 150	4 Maximum
225, 300	2 Maximum
450, 600, 900	1 (panel structure)

(*): The vector control (VM5) and V/f control (FM5) units are the same size.

No unit cooling fan

Cooling fans in each of the inverter and converter units have been eliminated; instead only the fans on the panel (panel top fans) are used for cooling. The reduced number of cooling fans subject to wear reduces the amount of maintenance work.

Enhanced maintainability

All the inverters can be maintained from the front panel. The inverter unit features a full plug-in structure, allowing built-in terminal blocks for external wires to be attached/detached collectively, while the power can be turned off on the motor side either electrically (via contactor) or manually (via breaker), or both.

Touch panel equipped with a liquid crystal display (*) (LCD)

Setting, running, monitoring and maintenance functions are all adjustable from the touch panel, equipped with a LCD on the unit front. The LCD displays various data as well as key operational guidance on the bottom, thus facilitating operation.

(*): Available in both Japanese and English (switchable)

FRENIC4000VM5
Vector control inverter
FRENIC4000FM5
V/f control inverter

Inverter panel external view



Enhanced support tools (option)

Analog output for chart, PC loader, web-based remote monitoring, a high speed data acquisition system and other support tools are enhanced.

Connectable to different transmission lines (option)

Connectable with a PLC or other high order controller at high speed and with limited wiring. In addition to Fuji's original D-line, T-link and SX bus, the PROFIBUS-DP, which is a typical open bus, is usable. It supports the transmission mode of the old FRENIC 4000 series models (VM2, VM3 and VM4).

Wide choice of plant control functions

Based on previous operational experiences in different plants to date, various control functions useful for plant control are provided.

Highly-effective plant operation

The DC-link system allows power operational and regenerative energy to be transmitted and received via a DC common bus for highly efficient plant operation.

Inverter panel (unit-type)



Common specifications

(*): Option

Type	Common to FRENIC4000VM5/FM5		
Main circuit system	Voltage-type IGBT sine wave PWM inverter		
Output voltage	3-phase, 400V AC		
Overload capability	150% for 1min		
Control function	Start/stop	Touch panel, Loader (*)	
	Key operation	Contact input, Analog input ($\pm 10V$)	
External signal	Transmission link operation	D-line/T-link (*), SX bus (*), PROFIBUS-DP (*)	
	Contact input	Built-in 12 points + 4 points (*) (2 points selectable $\times 1$, $\times 2$)	
Speed setting	Various transmission links, External signals, Touch panel, Loader (*) key operation		
Operation status signal	<ul style="list-style-type: none"> Relay output (built-in 9 points + 8 points (*)) 3 points selectable (Y1, Y2, Y3) Analog output (built-in 4 points + externally mounted 4 points (*) + built-in 2 points (*)) 		
Rotating motor pickup	The rotating motor is picked up in inverter operation (SY0).		
Restart after momentary power failure	Inverter is restarted without stopping the motor.		
Touch panel	Each constant setting, Startup conditions, Control data digital display, Fault cause display, Fault point data display		
Loader (*)	Setting item, Startup conditions, Control data digital display, Fault cause display, Fault trace data display (*1)		
Analog output	Analog output of arbitrary control data		
Charge lamp	Comes on when residual voltage (25V DC or larger) is in the main circuit.		
Protection	Protection level	Classified into the following 4 levels. <ul style="list-style-type: none"> Major fault: Trips instantly. Medium fault: Quickly decelerates and trips to stop after the set time has elapsed. Minor fault 1: Cannot be restarted once it is stopped. Minor fault 2: Display only 	
	Overvoltage	Actuated when the DC main circuit voltage exceeds 790V DC	
	Undervoltage	On detecting undervoltage of DC intermediate voltage, inverter stops.	
	Overheat	Protects the inverter by detecting the temperature of the heat sink inside the inverter.	
	Short-circuit	Detected by "overcurrent."	
	Overcurrent	Actuated when the output current peak value exceeds the overcurrent level (fixed).	
	Ground fault	By the operation of the converter side ground fault detection relay, inverter stops.	
	Motor (*2)	Protected by electronic thermal function and temperature detection. "Overload", "Motor overheat", "Startup congestion", "Overspeed"	
	Environment	Installation location	Indoors, Free from corrosive gas, inflammable gas, dust, or explosive gas
		Ambient temp.	0 to +40°C
Ambient humidity		20 to 90% RH (no condensation)	
Cooling method		Forced air-cooled system	
Altitude		Up to 1000m	
Vibration		4.9m/s ² or lower (at 10 to 50Hz)	
Storage (ambient temp.)	- 5 to +40°C		
Applicable standard	JEC-2410 (JIS, JEM, etc.)		

(*1): Stores and displays control data of 225 points for the past two 1ms sampling.
(*2): Only VM5 has the function of "motor overheat" and "overspeed" protection.

Individual specifications

(*): Option (**): To be developed

Type	FRENIC4000VM5		
Motor control system	<ul style="list-style-type: none"> Vector control Sensor-less vector control 		
Function	Speed control	ASR fixed cycle 1ms	
	Vector control	Maximum speed	200Hz on inverter output frequency basis
		Control range	1:1000
		Control response	40Hz (mechanical systems not included)
		Speed control accuracy	$\pm 0.005\%$ of the maximum speed
		Torque accuracy	$\pm 5\%$ of the rated torque, $\pm 3\%$ (VMT5) (*)
Sensor-less vector control	Maximum speed	200Hz on inverter output frequency basis	
	Control range	1:100 (0.5Hz or larger)	
	Control response	4Hz (mechanical systems not included)	
	Speed control accuracy	$\pm 0.5\%$ of the maximum speed	
	Torque accuracy	$\pm 5\%$ of the rated torque	
Setting resolution	$\pm 0.005\%$ of the max. speed (20000d/100%)		
Acceleration/deceleration time	0 to 550.00s Linear (break point) acceleration/deceleration Acceleration/deceleration settable by transmission 2 types of deceleration for emergency stop		
Control function	Multiplex winding motor driving	Up to 18 windings (6 multiplexing) without the output reactor	
	Start/stop operation selection	The timing for releasing the brake or starting ASR can be controlled by 3 different signals (SY1, 2 and 3 by transmission)	
	Droop control	Torque drooping characteristics according to the speed. A fixed drooping type or speed command proportional type.	
	Torque control	Torque limit (2 types of transmission) Torque compensation (Transmission 2 types + analog input 1 point) Mechanical loss torque is compensated by polygonal approximation with set value (forward/reverse: 14 points)	
	Torque bias	Analog torque setting, Transmission torque setting (2 lines), Mechanical loss pattern, etc.	
	Observer	Load disturbance observer Vibration suppression observer	
	Acceleration/deceleration forcing	Upon calculating the acceleration/deceleration torque based on the moment of inertia J and acceleration	
	Backlash correction	Corrects backlash during mechanical drive by several motors	
	Higher setting	Sets the speed higher than normal to cope with load impact	
	$\omega 2$ lock	Applies an electromagnetic brake during excitation to prevent the motor from needless rotation	
	di/dt limitation	Limits the gradient of the torque current command	
	Special braking	Stops the motor without regeneration (**)	
	Type	FRENIC4000FM5	
	Motor control system	V/f controlled AVR	
Function	Output frequency	2.5 to 200Hz	
	Frequency control range	1:80	
	Frequency control accuracy	$\pm 0.01\%$ of the maximum frequency	
	Field control range	1:4	
	Restart after momentary power failure	Inverter is restarted without stopping the motor.	

Transmission options

Card name	Use
DSM card	Connects the inverter with the host PLC via D-line, T-link
SX bus card	Connects the inverter with the host PLC via SX bus
PSB card	Connects the inverter with the host PLC via PROFIBUS-DP

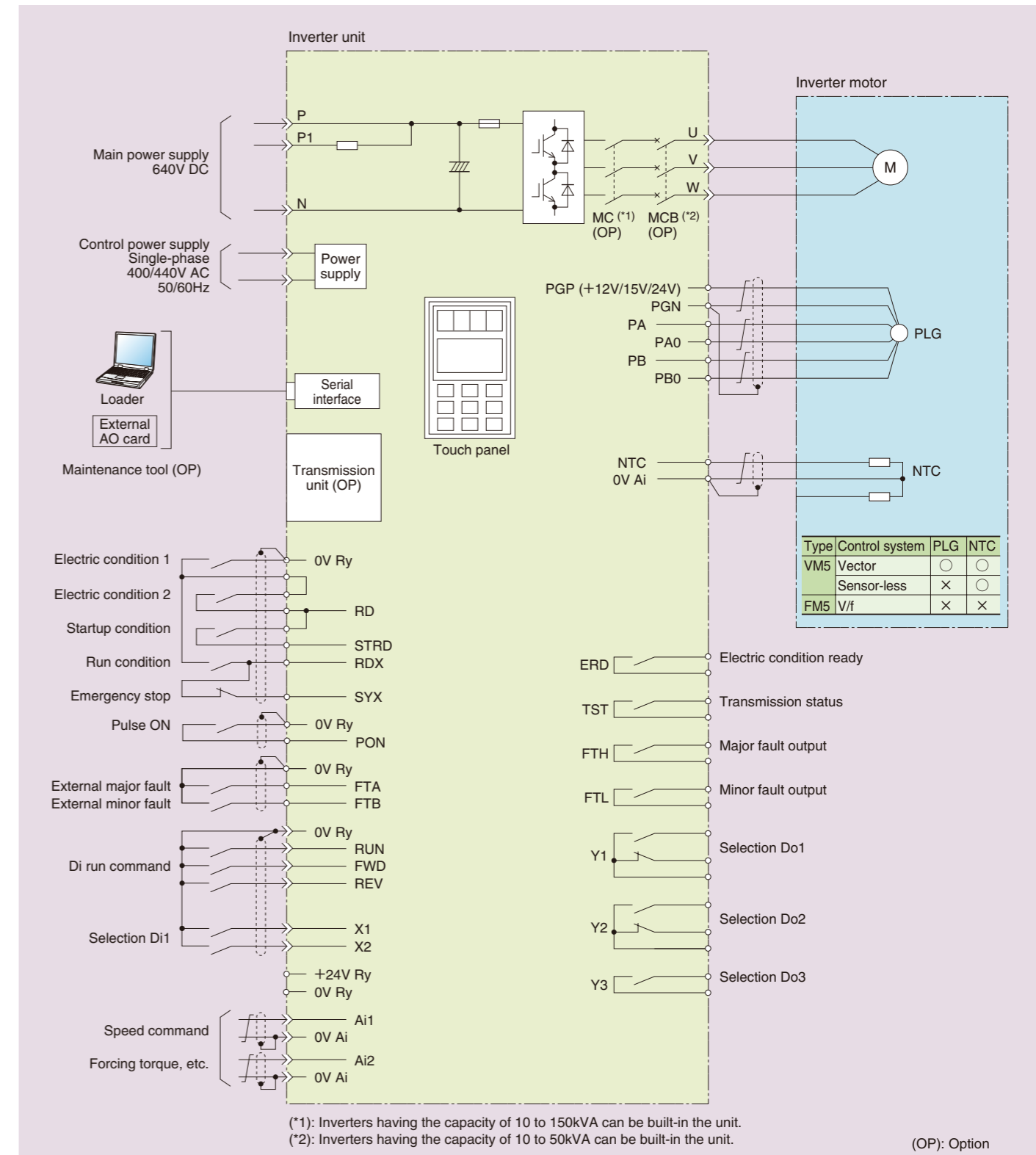

System configuration of inverter unit

VM5/FM5

System configuration of the FRENIC4000 series

Unit type (10 to 300kVA)

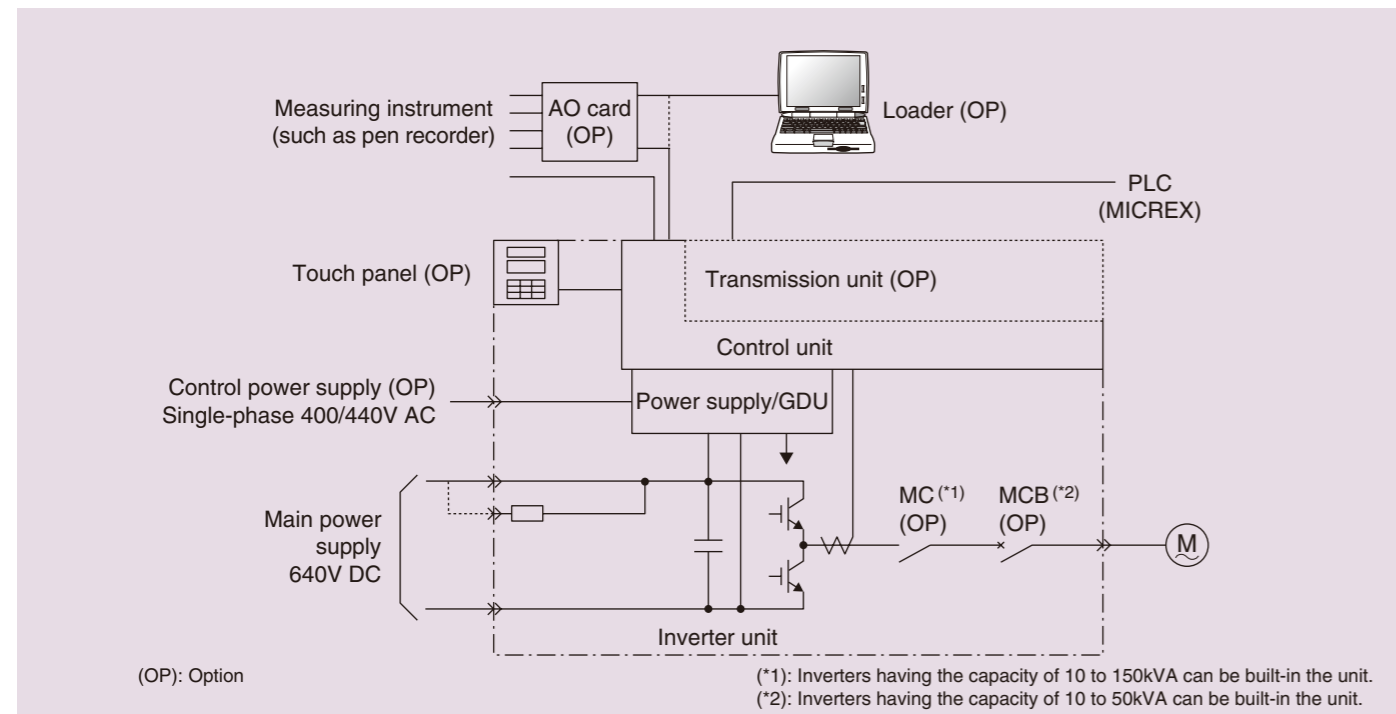

Large capacity type (450, 600, 900kVA)

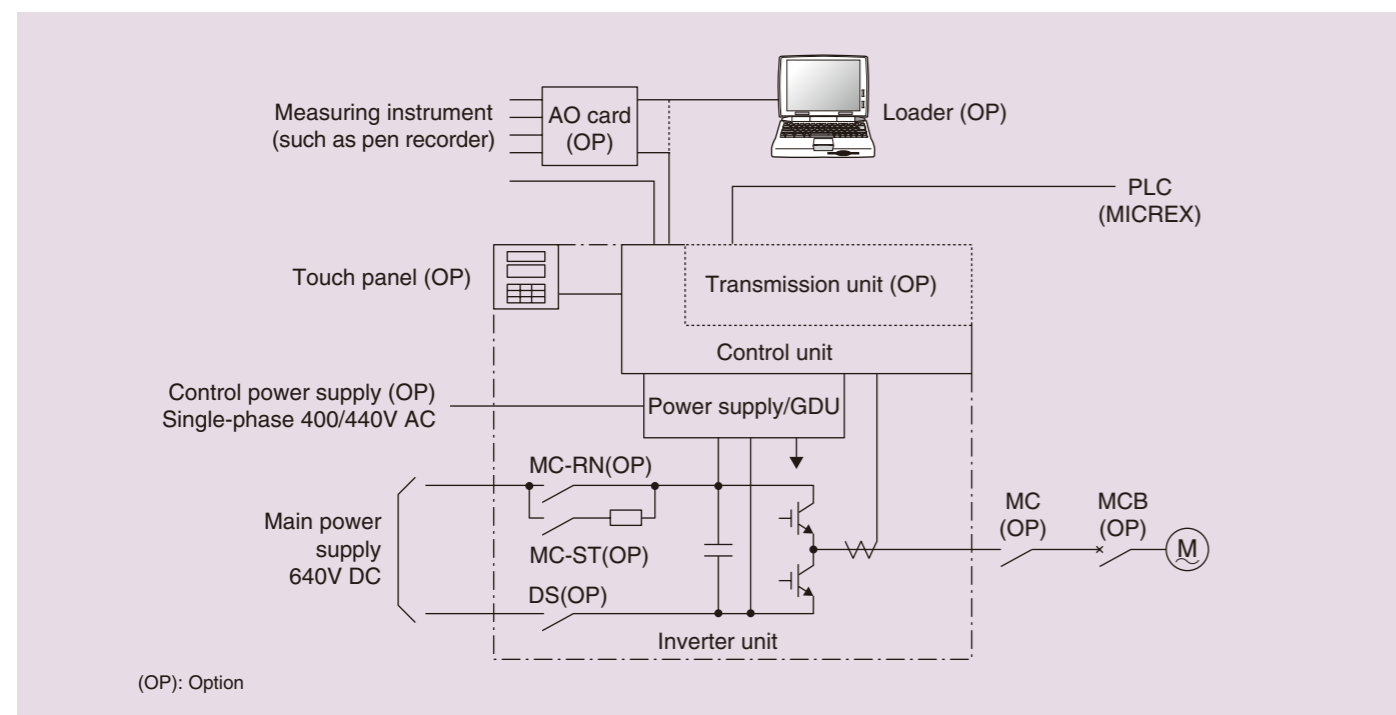

Example of system configuration and single-line diagram

VM5/FM5

System configuration

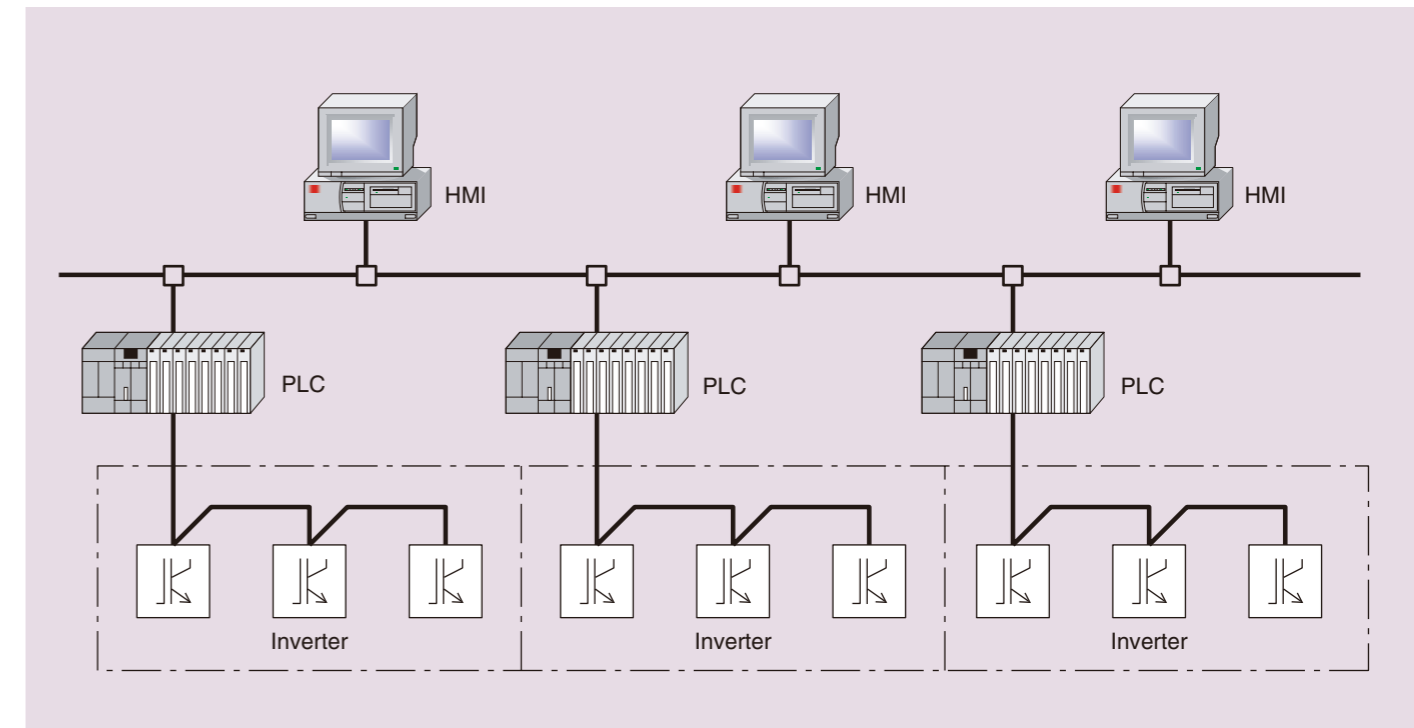

Single-line diagram

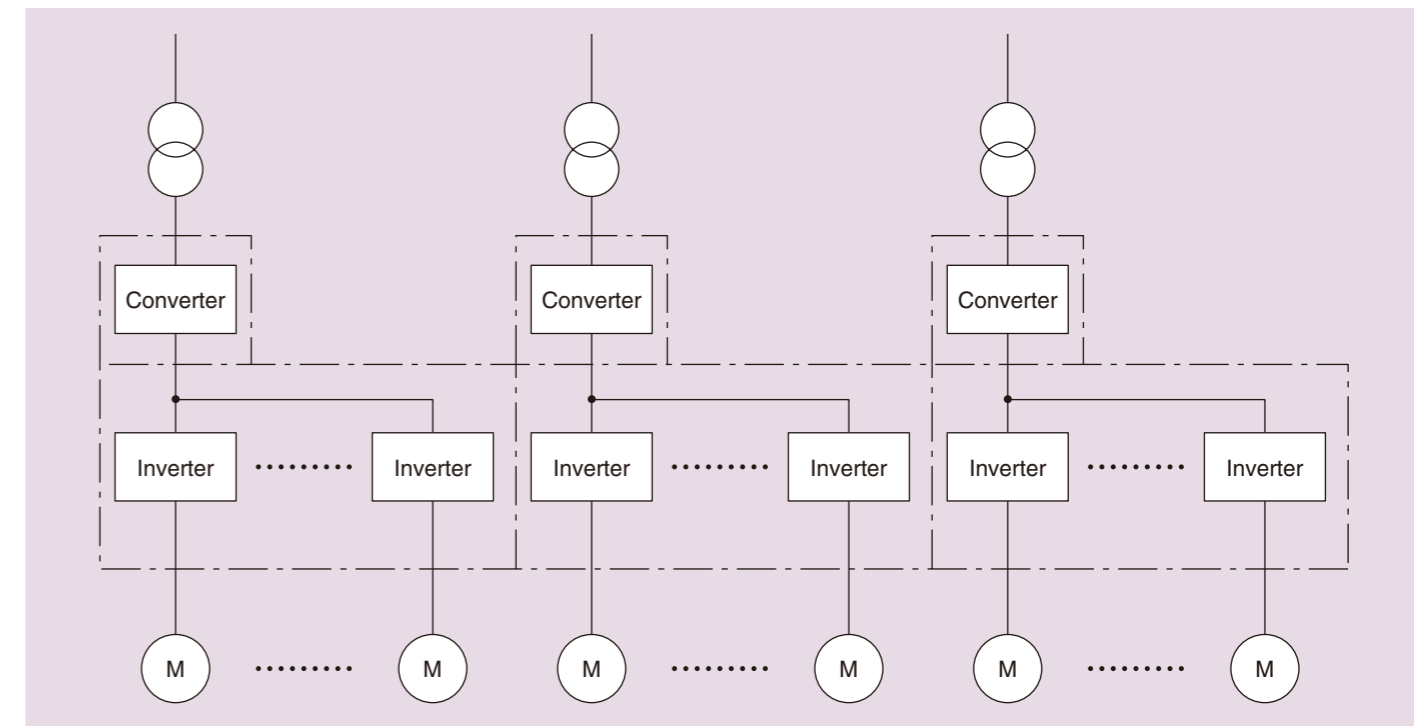

Inverter application and dimensions

VM5/FM5

Inverter unit types, rated currents, dimensions and masses

Unit type

Inverter capacity [kVA]	Type	Rated output current [A]	Approx. capacity of usable motor (*) [kW]	Max. unit dimensions W×D×H [mm]	Outline	Approx. mass [kg]	Control power supply capacity [VA] (when steady)	Max. No. of units/panel
10	RKPB100□-4VM5□ RKPB100□-4FM5□	14.4	5.5	656×551×140	①	20	60	12
15	RKPB150□-4VM5□ RKPB150□-4FM5□	21.7	7.5	656×551×140	①	20	60	12
25	RKPB250□-4VM5□ RKPB250□-4FM5□	36.1	15	656×551×140	①	25	60	12
38	RKPB380□-4VM5□ RKPB380□-4FM5□	54.8	22	656×551×210	①	30	65	8
50	RKPB500□-4VM5□ RKPB500□-4FM5□	72.2	30	656×551×210	①	35	65	8
75	RKPB750□-4VM5□ RKPB750□-4FM5□	108	45	656×551×210	①	40	65	8
100	RKPB101□-4VM5□ RKPB101□-4FM5□	144	55	656×551×420	①	60	80	4
150	RKPB151□-4VM5□ RKPB151□-4FM5□	217	90	656×551×420	①	70	80	4
225	RKPB221□-4VM5□ RKPB221□-4FM5□	325	132	656×551×840	①	110	80	2
300	RKPB301□-4VM5□ RKPB301□-4FM5□	433	160	656×551×840	①	120	80	2
Panel frame for above	—	—	—	900×650×2605 (800)	②	350	50Hz : 750 60Hz : 850	—

Panel type

Inverter capacity [kVA]	Type	Rated output current [A]	Approx. capacity of usable motor (*) [kW]	Panel dimensions W×D×H [mm]	Outline	Approx. mass [kg]	Control power supply capacity [VA] (when steady)	Remarks
450	RKPB451□-4VM5□ RKPB451□-4FM5□	650	270	800×650×2605	②	700	50Hz : 880 60Hz : 980	
600	RKPB601□-4VM5□ RKPB601□-4FM5□	866	360	800×650×2605	②	700	50Hz : 880 60Hz : 980	
900	RKPB901□-4VM5□ RKPB901□-4FM5□	1299	540	800×650×2695	②	750	50Hz : 1270 60Hz : 1410	
1200 (VM5 only)	RKPB122□-4VM5□	2×866	720	1600×650×2605	②×2	1400	50Hz : 1760 60Hz : 1960	Output reactor unnecessary
1800 (VM5 only)	RKPB182□-4VM5□	2×1299	1080	1600×650×2695	②×2	1500	50Hz : 2540 60Hz : 2820	Output reactor unnecessary
2700 (VM5 only)	RKPB272□-4VM5□	3×1299	1440	2400×650×2695	②×3	2250	50Hz : 3810 60Hz : 4230	Output reactor unnecessary
3600 (VM5 only)	RKPB362□-4VM5□	4×1299	1800	3200×650×2695	②×4	3000	50Hz : 5080 60Hz : 5640	Output reactor unnecessary
4500 (VM5 only)	RKPB452□-4VM5□	5×1299	2160	4000×650×2695	②×5	3750	50Hz : 6350 60Hz : 7050	Output reactor unnecessary
5400 (VM5 only)	RKPB542□-4VM5□	6×1299	3240	4800×650×2695	②×6	4500	50Hz : 7620 60Hz : 8460	Output reactor unnecessary

Note: The dimensions, masses and control power supply capacities shown are for standard specifications.

(*) : At rated current

Inverter unit

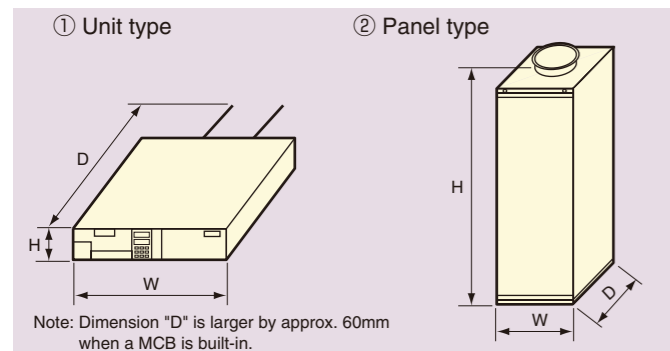

Inverter panel

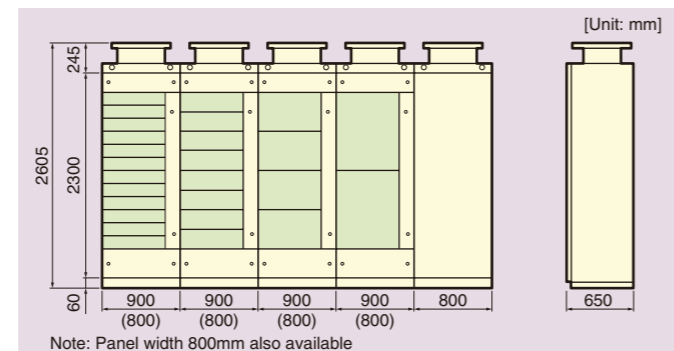

Common converter specifications and dimensions

VM5/FM5

- When regeneration function is generally unnecessary: Diode converter
- When the regenerative side capacity is smaller than that on the drive side: Combination of diode converter and PWM regenerative converter
- When regenerative capacity equivalent to that on the drive side is necessary: PWM converter (thyristor converter also available)

Specifications

Diode converter

Rated output current [A]	Rated capacity [kW] (at a rated value of 635V DC / 621V DC)	Without an initial charging circuit			With an initial charging circuit			Control power supply capacity [VA] (when steady)
		Panel dimensions W×D×H [mm]	Approx. mass [kg]	Fig.	Panel dimensions W×D×H [mm]	Approx. mass [kg]	Fig.	
225	143 / 140	800×650×2605	550	1	800×650×2605	600	1	2260
600	381 / 373	800×650×2605	650	1	800×650×2605	700	1	2260
1200	762 / 745	1100×650×2605	800	1	1700×650×2605	1100	2	2260
1800	1143 / 1118	1100×650×2605	850	1	1700×650×2605	1150	2	3390
2750	1746 / 1708	1100×1300×2605	1100	1	1100×1300×2605	1150	1	3520
4950	3143 / 3074	1900×1300×2605	1600	2	1900×1300×2605	1600	2	4650

Note: The dimensions, mass and control power supply capacity are based on standard specifications.

Thyristor converter

Rated output current [A]	Rated capacity [kW] (at 600V AC input / 620V DC output)	Panel dimensions W×D×H [mm]	Approx. mass [kg]	Fig.
2400	1440	1400×650×2605	1100	2

PWM converter

Rated capacity [kW] at 400V AC input	Rated capacity [kW] at 440V AC input	Panel dimensions W×D×H [mm]	Approx. mass [kg]	Control power supply capacity [VA] (when steady)		Fig.
30	35	800×650×2605	430	50Hz : 865	60Hz : 965	1
40	45	800×650×2605	430	50Hz : 865	60Hz : 965	1
60	65	800×650×2605	430	50Hz : 865	60Hz : 965	1
80	90	800×650×2605	430	50Hz : 880	60Hz : 980	1
125	135	800×650×2605	430	50Hz : 880	60Hz : 980	1
190	205	800×650×2605	450	50Hz : 880	60Hz : 980	1
250	275	800×650×2605	500	50Hz : 880	60Hz : 980	1
380	415	1600×650×2605	850	50Hz : 880	60Hz : 980	2
505	555	1600×650×2605	900	50Hz : 880	60Hz : 980	2
760	835	1600×650×2695	950	50Hz : 1270	60Hz : 1410	2
1010 (2 multiplex)	1110 (2 multiplex)	2400×650×2605	1400	50Hz : 1760	60Hz : 1960	3
1520 (2 multiplex)	1620 (2 multiplex)	2400×650×2695	1500	50Hz : 2540	60Hz : 2820	3

Note: The dimensions, mass and control power supply capacity are based on standard specifications.

PWM regenerative converter

Peak regenerative amount [kW]	Panel dimensions W×D×H [mm]	Approx. mass [kg]	Control power supply capacity [VA] (when steady)		Fig.
110	800×650×2605	430	50Hz : 880	60Hz : 980	1
165	800×650×2605	430	50Hz : 880	60Hz : 980	1
250	800×650×2605	450	50Hz : 880	60Hz : 980	1
330	800×650×2605	500	50Hz : 880	60Hz : 980	1
500	1600×650×2605	850	50Hz : 880	60Hz : 980	2
660	1600×650×2605	900	50Hz : 880	60Hz : 980	2
1320 (2 multiplex)	1600×650×2695	950	50Hz : 1270	60Hz : 1410	2
1980 (3 multiplex)	2400×650×2605	1400	50Hz : 1760	60Hz : 1960	3

Note: The dimensions, mass and control power supply capacity are based on standard specifications.

Dimensions

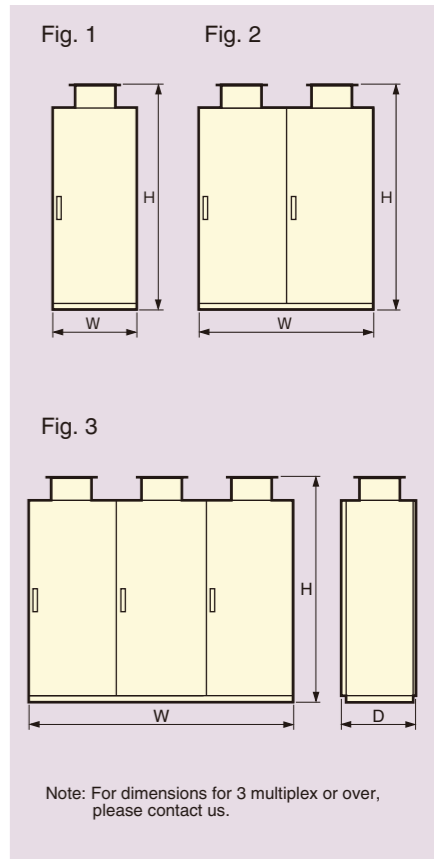

Common specifications

Environment	Installation location	Indoors, Free from corrosive gas, inflammable gas, dust, or explosive gas
	Ambient temp.	0 to +40°C
	Ambient humidity	20 to 90% RH (no condensation)
	Cooling method	Forced air-cooled system
	Altitude	Up to 1000m
	Vibration	4.9m/s ² or lower (at 10 to 50Hz)
	Storage (ambient temp.)	-5 to +40°C
	Applicable standard	JEC-2410 (JIS, JEM, etc.)

Dimensions and mass of DC/AC reactors and regenerative transformer

VM5/FM5

Specifications

Diode converter

Rated output current [A]	Separate DC reactor			
	Standard type (*1)	Dimensions W×D×H [mm]	Approx. mass [kg]	Fig.
600	RKJP1DLK-0094A	Contact us	Contact us	1
1200	RKJP1DLK-0094B			
1800	RKJP1DLK-0094C	615×850×1015	270	1
2750	RKJP1DLK-0094E	615×1000×1115	375	1
4950	RKJP1DLK-0094H	800×1100×1310	550	1

(*1): The DCL type is for reference. The selected type depends on particular specifications.

PWM converter

Rated capacity [kW] at 400V AC input	Separate AC reactor			
	Standard type (*2)	Approx. dimensions W×D×H [mm]	Approx. mass [kg]	Fig.
30	RKJP1ALK-0083R or S	Contact us	Contact us	2
40	RKJP1ALK-0083T or U			
60	RKJP1ALK-0083V or W			
80	RKJP1ALK-0083A or H			
125	RKJP1ALK-0083B or J			
190	RKJP1ALK-0083C or K	665×665×1065	340	2
256	RKJP1ALK-0083D or L	665×665×1065	370	2
380	RKJP1ALK-0083F or N	750×700×1005	420	2
500	RKJP1ALK-0083G or P	915×765×1065	510	2
760	RKJP1ALK-0083X or Y	900×900×1380	840	2
1000 (2 multiplex)	RKJP1ALK-0083G,P×2	915×765×1065×2	510×2	2
1520 (2 multiplex)	RKJP1ALK-0083X,Y×2	900×900×1380×2	840×2	2

(*2): Type depends on the particular source frequency and whether the leads are present or not (F).

PWM regenerative converter

Peak regenerative amount [kW]	Separate regenerative transformer			
	Standard type	Approx. dimensions W×D×H [mm]	Approx. mass [kg]	Fig.
110	RKJP1TRK-0065GP	Contact us	Contact us	3
165	RKJP1TRK-0065HP			
250	RKJP1TRK-0065IP	800×800×1165	450	3
330	RKJP1TRK-0065JP	800×800×1165	525	3
500	RKJP1TRK-0065KP	900×900×1375	685	3
660	RKJP1TRK-0065LP	900×900×1375	830	3
1320 (2 multiplex)	RKJP1TRK-0065LP×2	900×900×1375×2	830×2	3
1980 (3 multiplex)	RKJP1TRK-0065LP×3	900×900×1375×3	830×3	3

Separate DC reactor

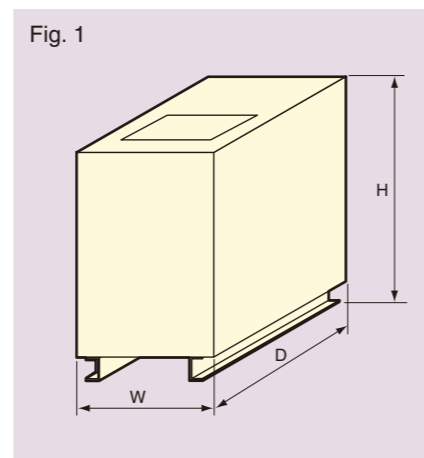

Separate AC reactor

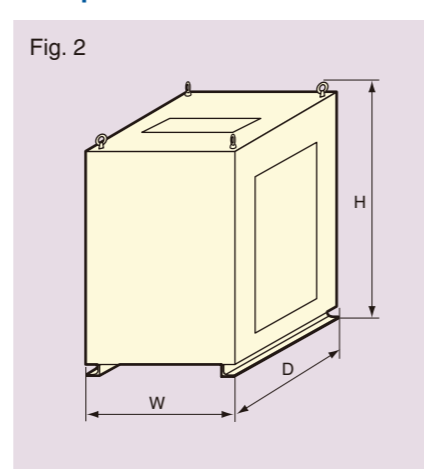

Separate regenerative transformer

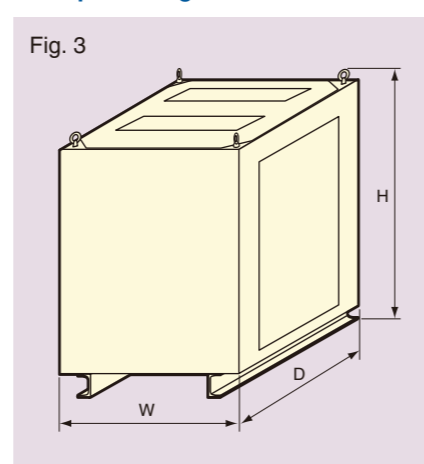

Recommended cable for inverter and converter

VM5/FM5

Inverter

(*): furnished

Inverter capacity [KVA]	Rated current [A]	Overload current [A] (1min)	Position	Main circuit (inverter ⇔ motor)			Control	
				Connectable cable		Terminal	Inverter relay unit	
				No./each phase	Phase	Size [mm ²]	Screw size	Screw size
10	14.4	21.7	⑤	1	Three	3.5 to 8	M5 (*)	M3.5 (*)
15	21.7	32.5						
25	36.1	54.1						
38	54.8	82.3						
50	72.2	108.3				3.5 to 38	M8 (*)	
75	109	163						
100	144	217						
150	217	325				3.5 to 100	M10 (*)	
225	325	487						
300	433	650				80 to 325	M16 (*)	
450	650	974						
600	866	1299						
900	1299	1949						
			2	Three				
			4	Three				

Diode converter

(*): furnished

Converter rated output current [A]	Rated current [A]	Overload current [A] (1min)	Position	Main circuit (incoming ⇔ converter)					
				Connectable cable			Terminal		
				No./each phase	Phase	Size [mm ²]	Shape	Screw size	
225	183	275	①	1	Three	80 to 325	Copper bar	M16 (*)	
	225	337							2
600	490	735		②	2				Three
	600	900							
1200	980	1470		③	3				Three
	1200	1800							
1800	1471	2207		①	5				Three
	1800	2700							
2750	2247	3371		①	8				Three
	2750	4125							
4950	4044	6066	①	16	Three				
	4950	7425				②	20	Single	

PWM regenerative converter

(*): furnished

Converter capacity [kW]	Max. current I _p (Note 1) [A]	Position	Main circuit			Control	
			Connectable cable		Terminal	Terminal block	
			No./each phase	Phase	Size [mm ²]	Screw size	Screw size
110	217	③	1	Three	3.5 to 100	M10 (*)	M3 (*)
165	325						
250	487				80 to 325	M16 (*)	
330	650						
500	974						
660	1299	2	Three				
n×660	n×1299	n×2	Three				

PWM converter

(*): furnished

Converter capacity [kW]	400V AC input	440V AC input	Rated current [A] (AC side)	Overload current [A] (1min)	Position	Main circuit (incoming ⇔ converter)				Control	
						Connectable cable		Terminal		Relay unit	
						No./each phase	Phase	Size [mm ²]	Screw size	Screw size	Screw size
30	35	54	81	④	1	Three	3.5 to 38	M8 (*)	M3.5 (*)		
40	45	72	108								
60	65	108	162								
80	90	144	217								
125	135	217	325				3.5 to 100	M10 (*)			
190	205	325	488								
250	275	433	650								
380	415	650	974				80 to 325	M16 (*)			
505	555	866	1299								
760	835	1299	1949				2	Three			
				4	Three						

Diode converter + inverter + PWM regenerative converter

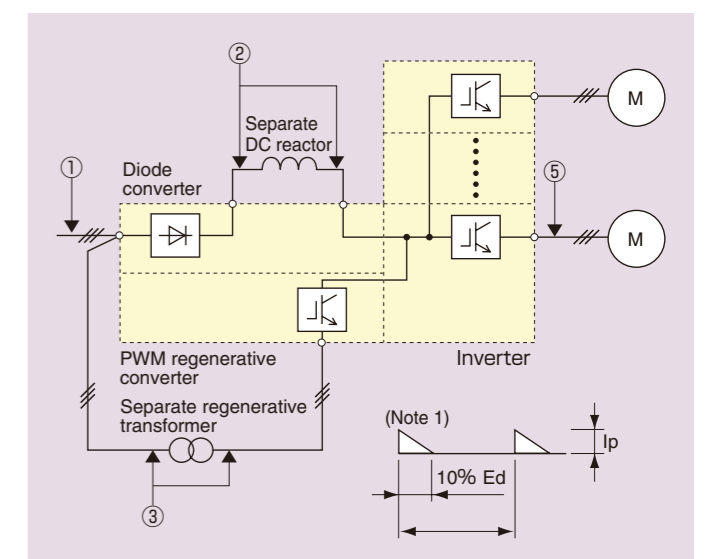

PWM converter + inverter

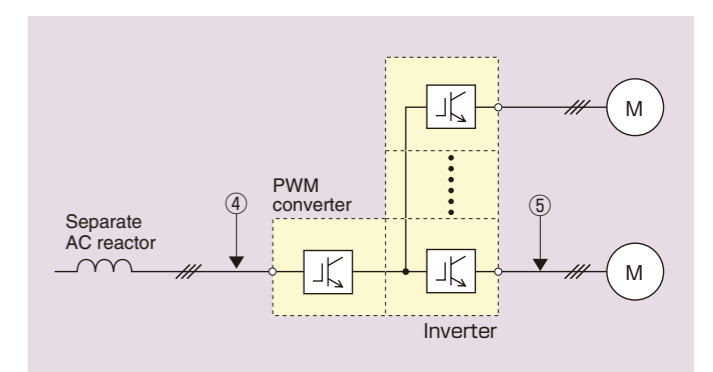

Data setting and monitoring (dedicated touch panel)

VM5/FM5

The touch panel equipped with a LCD displays a lot of information, and facilitates the functions of data setting, running operation and monitoring. On the bottom of the LCD, key operational guidance appears, allowing you to perform almost all operations without referring to the instruction manual.

Up and down keys

Used for changing the Data Indication Nos. and the data setting values.

Program key

Reverts to the monitor screen (default) from any screen.

Shift key (digit shift)

Used to move the cursor from one digit to another in order to change data.

Reset key

When normal:
Assigned to "return" and "cancel" functions.
Returns to the previous layer.
At tripping:
Releases the stop status due to tripping.

Function/data selection key

Assigned to "enter" and "OK" functions.



Example of actual screen display

The monitor screen (default screen after turning on power) continually displays all of the current running statuses: speed command, detection, output current, output voltage and key operational guidance.

LED monitor (4 digits)

Displays the number of revolutions (changeable). Any of 8 different data indicated on the LCD on the monitor screen can be selected arbitrarily. At tripping: "Err" blinks automatically, alerting you to the trip.

LCD monitor

Displays various information, including operational, set and fault data over a maximum of 5 lines × 13 characters. Operational guidance appears on the bottom. On tripping, the trip data automatically appears.

Normal, reverse and stop keys

The operation can be started or stopped on the touch panel.

Use of touch panel (the No. of items is for VM5)

Menu	Description	No. of items
Initial	Monitor screen: Current, voltage and frequency display	Selected out of 2 pictures
M01	Parameter setting reference and change	About 200
M02	Di/Do bit on/off status reference	7 pictures
M03	Ai/Ao voltage reference	2 pictures
M04	Inverter internal data display	About 90
M05	Transmission, sent/received data reference	About 60
M06	Inverter start, stop operation	1 picture
M07	Inverter startup condition on/off reference	2 pictures
M08	Latest fault code (simultaneous occurrence) reference	Up to 20
M09	Error history reference	Latest 40
M10	Inverter inside data reference on trip	About 20
M11	Present time setting, operating time reference, parameter setting control, liquid crystal concentration adjustment, etc.	About 10 pictures

Introduction of some functions

●M09: Error history

Displays a chronological record of the past 40 faults with the causes and the time and date of occurrence, thereby allowing you to trace back errors.

●M10: Trip data display

Displays internal data sampling values and bit data on/off, allowing you to know the fault circumstances.

●M11: Save of parameter settings, load, and comparison

Inverter parameter settings can be saved in batch form into nonvolatile memory using the touch panel. They are retained when the power is turned off. The saved data can also be loaded to the inverter. Current inverter settings and values saved on the touch panel can be compared with each other.

Maintenance tool (option)

VM5/FM5

■ PC loader (FLOAD for Windows)

Although maintenance and adjustment can be performed from the touch panel mounted on the panel face, an optional PC loader is available as a maintenance/adjustment tool. The PC loader installed in a notebook PC, has better operability and visibility than the touch panel. The trace-back data is useful for locating any fault trip.

●Main functions of FLOAD for Windows

●Trace-back data

Upon fault occurrence, the cause as well as the waveform data and bit on/off statuses of the speed, current and other major items are registered. You can proceed to analysis of error circumstances, quick action and recovery. Details of up to 2 of the latest error occurrences can be retained.

●Control parameter setting, change, display and storage

Control parameter settings can be saved with arbitrary filenames and comments and changed on a PC. Thus, the inverter control parameters can be controlled on a PC.

●Running status display

Current inverter running statuses can be viewed at a glance thanks to the block diagram, actual value and internal data indications.

●Fault cause display

Up to 2 faults with up to 20 causes each are indicated together with the time and date of occurrence.

●Test run operation

The loader facilitates easy start and stop of the inverter while its statuses are displayed on the "running status indication screen".

●Multi-window display

Several window indications can be displayed on a single screen, thereby allowing you to simultaneously monitor multiple information sources.

■ External AO card (type: RGGW1AAU-0070D)

Inverter internal data (signal selection out of about 60 data) can be outputted by 4 channels in ±10V of analog voltage. They are isolated from the inverter.

■ Special lifter (type: FC33022)

The inverter can be replaced by a small number of persons. The inverter, as well as the converter, in each capacity can be handled upon changing the load bucket.

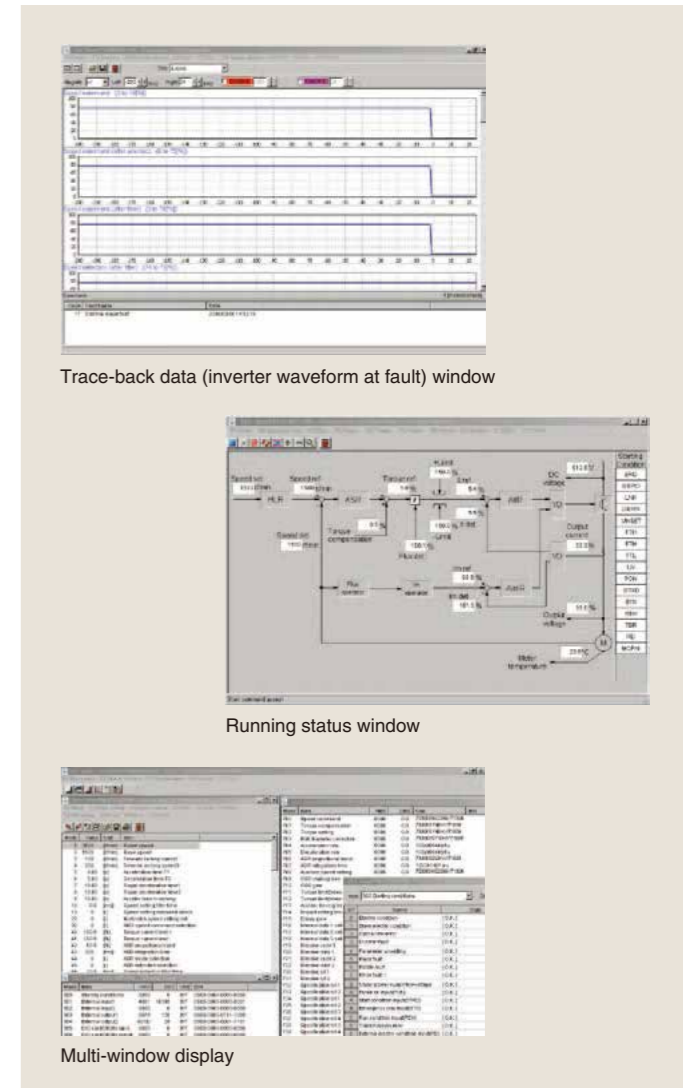

plusFSITE (*1) (Field Web adapter)

This adapter enables users to carry out remote monitoring of inverters promptly and easily with their own personal computers without using a dedicated system.

Main features

- Web server function
Inverters can be monitored from the browser of a personal computer. (Display screen can be changed if requested.)
- Mail sending function
Actions can be reported periodically from inverters. Upon fault occurrence, mail, including trace-back data, is transmitted.
- Applicable to the FRENIC4000VM5/FM5 and other Fuji Electric products.

(*1): plusFSITE: Fuji Supervising Interface Terminal for various Equipment



f(s)NISDAS (*2)

The inverter monitoring can be centralized at high speed.

Main features

- Real time monitoring
Inverter data can be sampled every 10ms (for up to 32 inverters simultaneously).
- Trace-back data acquisition
Trace-back data stored in the inverter can be acquired.
- PLC internal data acquisition
Fuji general-purpose PLC (MICREX-SX) internal data can be acquired.

(*2): f(s)NISDAS: Using open-Network & I.T., based on SX, Diagnosis and Analysis System

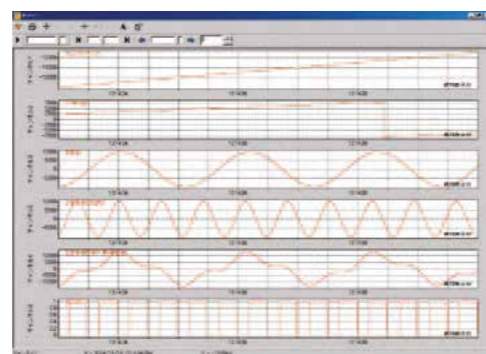

Example of system configuration

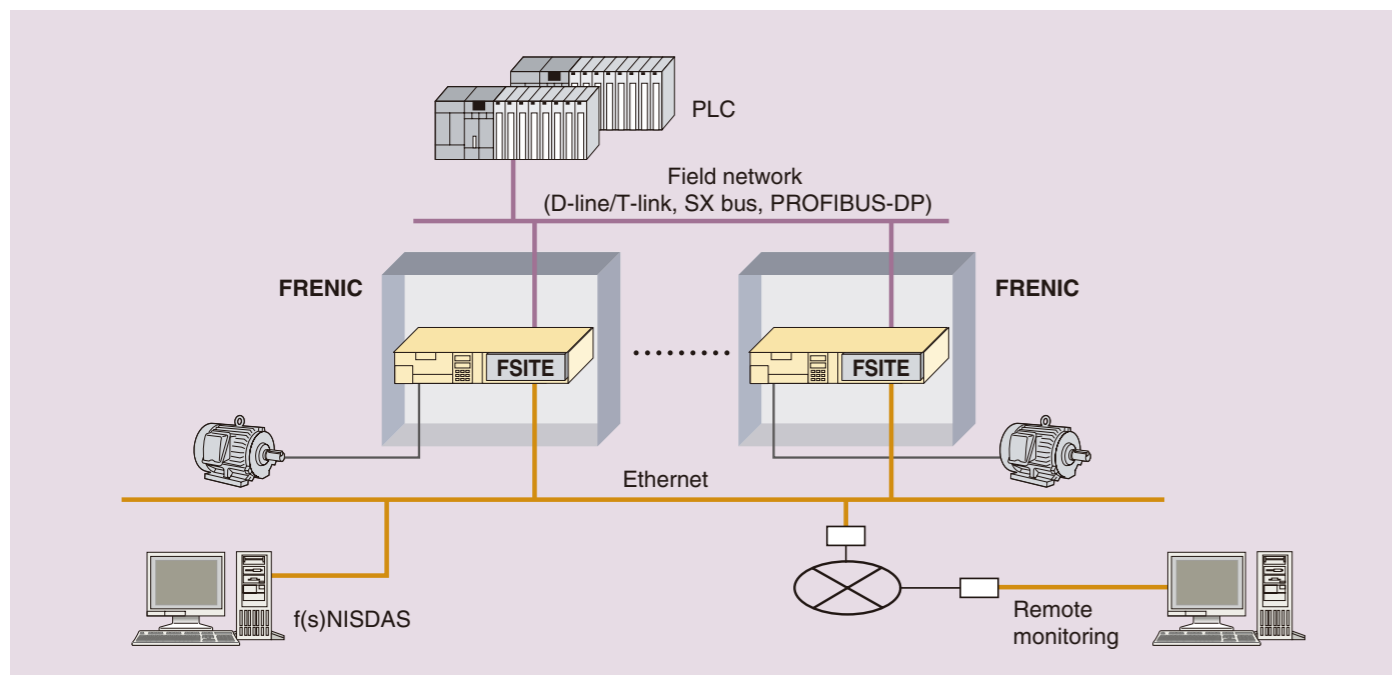

Application	Series	Features	Output voltage [V]	Capacity range [kVA]			
				10	100	1000	10000
For plant	FRENIC 4000VM5	Vector controlled inverter for plants • High-performance vector control system for quick response, high-accuracy and wide range speed control. • The DC-link system allows highly efficient plant operation.	400	5400			
	FRENIC 4000FM5	V/f controlled inverter for plants • Frequency of fan, pump and group-driven motors can be controlled accurately. • The DC-link system allows highly efficient plant operation.	400	900			
	FRENIC 4400VM5	Large-capacity vector controlled inverter • The capacity of FRENIC4000 series units has been increased due to 3-level control.	800	6000			
	FRENIC 4400FM5	Large-capacity V/f controlled inverter • The capacity of FRENIC4000 series units has been increased due to 3-level control.	800	2000			
	FRENIC 4700VM5	Medium-voltage large-capacity vector controlled inverter • The capacity of FRENIC4000 series units has been increased thanks to the series-connected device and 3-level control.	3440	7800			
	FRENIC 4800VM5	Medium-voltage, water-cooling, large-capacity and vector controlled inverter • The capacity of FRENIC4000 series units has been increased due to 3-level control. • Downsizing achieved by adopting a water-cooling system	3100	24000			
	LEONIC-M700	Thyristor converter for plants • Large-capacity thyristor converter for various types of control	220 DC 440 DC 750 DC	...			
	LEONIC-M Compact	Unit-type DC motor controller • Compact thyristor controller equipment intended for update from analog controller also	220 DC 440 DC	75kW 150kW			
For general industry (medium-voltage)	FRENIC 4600FM5	Medium-voltage direct-output inverter • 3.3/6.6kV IGBT inverter • Variable speed operation of medium-voltage motors saves energy. • Circuit configuration and control are well designed for power supplies and motors.	3300 6600	3750 7500			
	FRENIC 4600FM5e	Medium-voltage direct-output inverter (for fans and pumps) • Compact • Variable speed operation of medium-voltage motors saves energy. • Circuit configuration and control are well designed for power supplies and motors.	3300 6600 10000	5200 10500 5300			
For general industry (low-voltage)	FRENIC 5000VG7S	High-performance vector controlled inverter	200 400	90kW 800kW			
	FRENIC-MEGA	High-performance V/f controlled inverter	200 400	90kW 630kW			
	FRENIC-ECO	V/f controlled inverter for fans and pumps	200 400	110kW 560kW			

Ordering information

When placing an order or making an inquiry, please state the following.

Application of inverter		Remarks:
Load machine specifications		
Name:		
Load torque characteristics: <input type="checkbox"/> Square-law speed <input type="checkbox"/> Constant torque <input type="checkbox"/> Constant output		
Moment of load inertia after conversion into motor shaft (J): kg · m²		
Overload: %		
Input specifications		
Rated voltage: V ± %	Rated frequency: Hz ± %	
Control power source: -phase, -wire, V, Hz		
Driven motor		
Motor specifications: <input type="checkbox"/> Squirrel-cage rotor <input type="checkbox"/> () , <input type="checkbox"/> Existing <input type="checkbox"/> New installation		
Rating	Output: kW No. of poles: kV	
	Frequency: Hz Speed: r/min Current: A	
Speed control		
Control range: r/min to r/min		
Rotational/frequency setting method		
Ambient conditions		
Installation location: Indoor	Humidity: %RH Temperature: °C Altitude: m	
Provision of air conditioning: Limit on carrying-in:		

Fuji Electric India Pvt. Ltd.

(CIN:U31900TN1985PTCO11866)

119, 120, 120A, Electrical and Electronics Industrial Estate,
Perungudi, Chennai - 600 096, Tamil Nadu, India

+91 78100 09955

enquiry.fei@fujielectric.com | info-fei@fujielectric.com

www.india.fujielectric.com



Scan QR code for
Service support

Authorized Channel Partner

